



Advancing the Gold-Copper Gabbs Project

September 2024

TSX-V:PGLD / OTCQB:PGLDF

Cautionary Statement



Forward-Looking Information

This presentation contains "forward-looking information" within the meaning of applicable securities laws that is intended to be covered by the safe harbors created by those laws. "Forward-looking information" includes statements that use forward-looking terminology such as "may", "will", "expect", "anticipate", "believe", "continue", "potential" or the negative thereof or other variations thereof or comparable terminology. Such forward-looking information includes, without limitation, the Company's expectations, strategies and plans for the Gabbs Project and BAM Project, including the Company's planned expenditures and exploration activities.

Forward-looking information is not a guarantee of future performance and is based upon a number of estimates and assumptions of management at the date the statements are made. Furthermore, such forward-looking information involves a variety of known and unknown risks, uncertainties and other factors which may cause the actual plans, intentions, activities, results, performance or achievements of the Company to be materially different from any future plans, intentions, activities, results, performance or achievements expressed or implied by such forward-looking information. See "Risk Factors" in the Company's annual information form for the year ended December 31, 2023, dated March 21, 2024 filed on SEDAR+ at www.sedarplus.com for a discussion of these risks.

The Company cautions that there can be no assurance that forward-looking information will prove to be accurate, as actual results and future events could differ materially from those anticipated in such information. Accordingly, investors should not place undue reliance on forward-looking information. Except as required by law, the Company does not assume any obligation to release publicly any revisions to forward-looking information contained in this presentation to reflect events or circumstances after the date hereof.

Quality Assurance

The Gabbs Project April 2024 Updated Mineral Resource Estimate was prepared under the supervision of Eugene Puritch, P.Eng., FEC, CET of P&E Mining Consultants Inc. ("P&E") of Brampton, Ontario, who is an Independent Qualified Person ("QP"), as defined by National Instrument 43-101, Standards of Disclosure for Mineral Projects ("NI 43-101"). See the Company's news release dated April 29, 2024.

The Gabbs Project updated preliminary economic assessment was prepared by Kappes, Cassiday & Associates ("KCA") of Reno, Nevada with Mineral Resource and geological/mining contributions from P&E in accordance with NI 43-101. See the Company's news release dated May 22, 2024.

The Company filed a NI 43-101 technical report entitled "NI 43-101 Technical Report, Preliminary Economic Assessment, Gabbs Heap Leach and Mill Project, Nye County, Nevada, USA", with an effective date of May 17, 2024 (the "Gabbs Technical Report"). The Gabbs Technical Report is available under the Company's profile on SEDAR+ at www.sedarplus.com and on the Company's website at www.p2gold.com. The Gabbs Technical Report was prepared by Carl E. Defilippi, RM, SME of KCA, Eugene Puritch, P.Eng., FEC, CET, Andrew Bradfield, P.Eng., William Stone, Ph.D., P.Geo., Jarita Barry, P.Geo. and David Burga, P.Geo. of P&E and Douglas Willis, CPG of Welsh Hagen Associates of Reno Nevada, each of whom is a "Qualified Person" as defined by NI 43-101 and independent of the Company.

Ken McNaughton, P.Eng. is the qualified person responsible for the Gabbs Project and BAM Project and has reviewed, verified and approved the scientific and technical information in this presentation relating to the Gabbs Project and BAM Project. Mr. McNaughton is the Chief Exploration Officer and a Director of the Company and is a "Qualified Person" as defined by NI 43-101.

Currency

Unless otherwise indicated, all dollar values herein are in Canadian dollars.

Advancing the PEA-stage, gold-copper Gabbs Project in Nevada to production

Experienced management team that discovered and built the Brucejack Mine in British Columbia

Management aligned with shareholders:
24.4% management ownership

P2 Gold's Proven Management Team



Joe Ovsenek

President & CEO, Chair

- Over 30 years in precious metals, building companies and leading growth from early exploration stage to production
- Former President and CEO of Pretium Resources Inc.
- Prior to Pretium, 15 years in senior management roles for Silver Standard Resources Inc.



Ken McNaughton

Chief Exploration Officer

- Over 30 years of global experience developing and leading precious metals mineral exploration programs
- Former Chief Exploration Officer of Pretium Resources Inc.
- Prior to Pretium, 20 years as Vice President, Exploration at Silver Standard Resources Inc.



Michelle Romero

Executive Vice President

- Over 20 years in precious metals leading corporate teams making transition from exploration to production
- Former Executive Vice President, Corporate Affairs and Sustainability of Pretium Resources Inc.
- Prior to Pretium, Director, IR of Silver Standard Resources Inc.



Grant Bond

CFO

- Over 15 years of professional financial experience. Former Corporate Controller of Pretium Resources Inc.
- Managed accounting/financial reporting functions and SOX internal control framework as Pretium evolved from an explorer to intermediate gold producer
- Began his career at PricewaterhouseCoopers LLP.

Gabbs Project

Advancing to Production in Nevada

Gold and Copper with Excellent Infrastructure

- May 2024 PEA completed
- Accessible by paved highway with power line crossing the Project
- Gold Equivalent Mineral Resource⁽¹⁾ (gold & copper)
 - 1.16 M oz Indicated
 - 2.29 M oz Inferred
- 543 lode mining claims (BLM) and one patented claim covering approximately 45.25 km² (16 square miles)



(1) Indicated Mineral Resource Gold Equivalent comprised of 49.8 million tonnes grading 0.45 g/t gold, 1.36 g/t silver and 0.27% copper and Inferred Mineral Resource Gold Equivalent comprised of 112.2 million tonnes grading 0.35 g/t gold, 0.84 g/t silver and 0.23% copper.

Gabbs Project

Advancing to Production in Nevada



Gabbs Project 2024 PEA Economics⁽¹⁾

	Low Case	Base Case	High Case	Spot Case ⁽²⁾
Gold Price (US\$/oz)	\$1,800	\$1,950	\$2,100	\$2,414
Silver Price (US\$/oz)	22.50	25.00	27.50	31.48
Copper Price (US\$/lb)	\$4.00	\$4.50	\$5.00	\$4.71
Net Revenue (US\$)	\$4.2 billion	\$4.6 billion	\$5.0 billion	\$5.4 billion
After tax NCF ⁽³⁾ (US\$)	\$769.3 million	\$1.1 billion	\$1.5 billion	\$1.7 billion
After tax NPV5 ⁽³⁾ (US\$)	\$326.8 million	\$550.0 million	\$768.7 million	\$949.2 million
After tax NPV10 ⁽³⁾ (US\$)	\$104.7 million	\$257.0 million	\$405.3 million	\$530.0 million
After tax IRR ⁽³⁾ (%)	14.4%	21.0%	27.4%	33.5%
Payback ⁽⁴⁾ /Mine Life (years)	4/14.2	3/14.2	2/14.2	1.7/14.2

(1) See P2 Gold news release dated May 22, 2024

(2) As of May 17, 2024

(3) NCF means net cash flow; NPV5 means net present value discounted at 5%; NPV10 means net present value discounted at 10%; IRR means internal rate of return

(4) Preproduction capital

Gabbs Project 2024 PEA Plan of Operations⁽¹⁾

Years 1 – 5

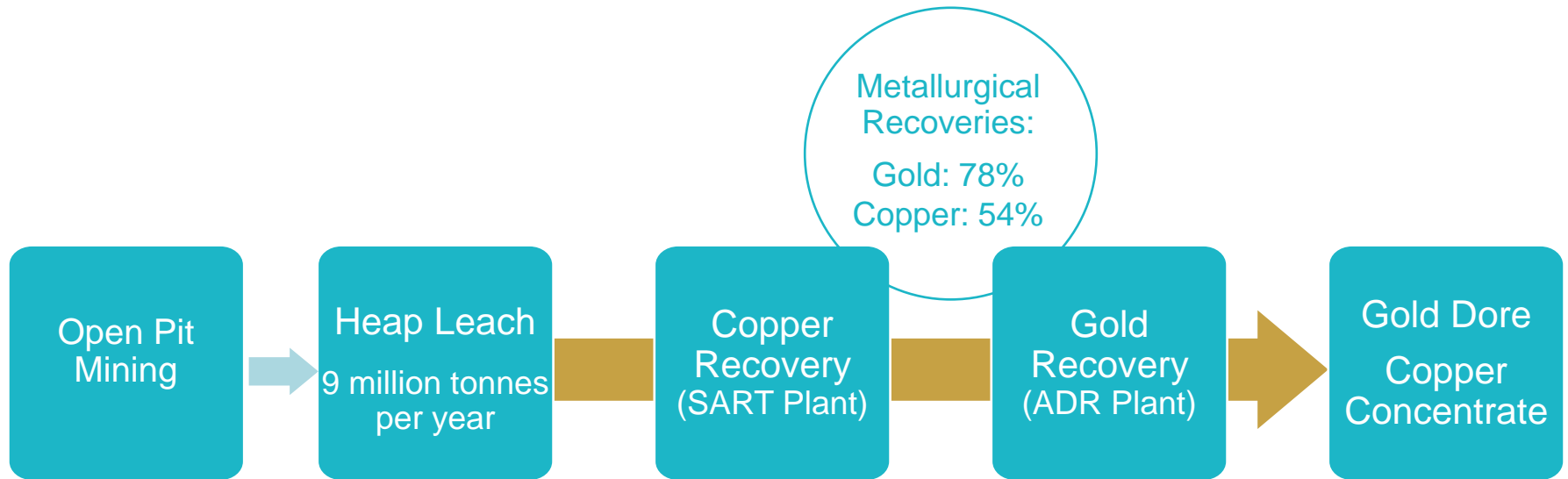

(1) See the Gabbs Technical Report dated May 17, 2024 available under the Company's profile on SEDAR+ at www.sedarplus.com and on the Company's website at www.p2gold.com.

Gabbs Project Advancing to Production in Nevada

Gabbs Project Flow Sheet Crushing & Heap Leach (Years 1 - 5)⁽¹⁾

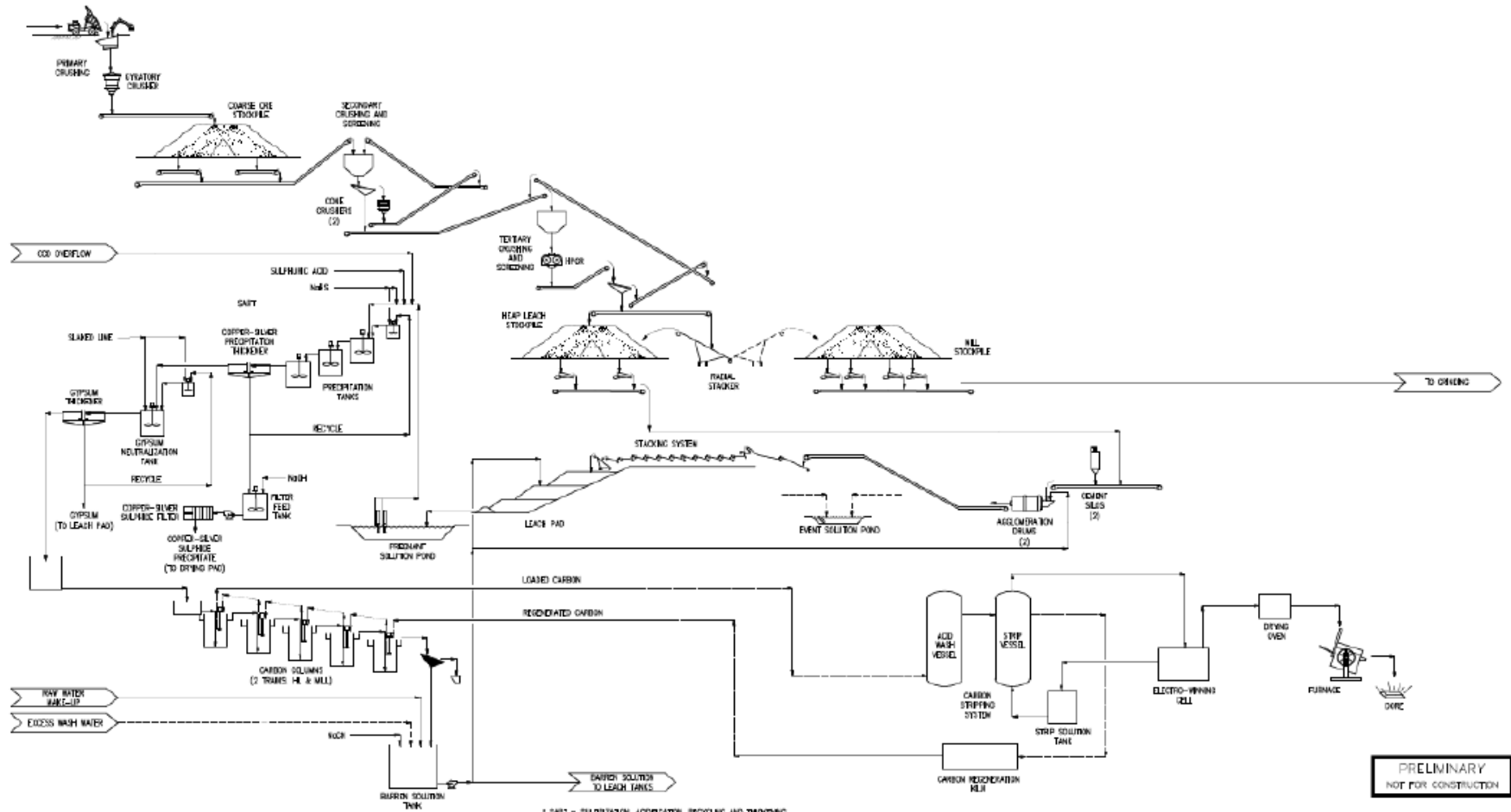
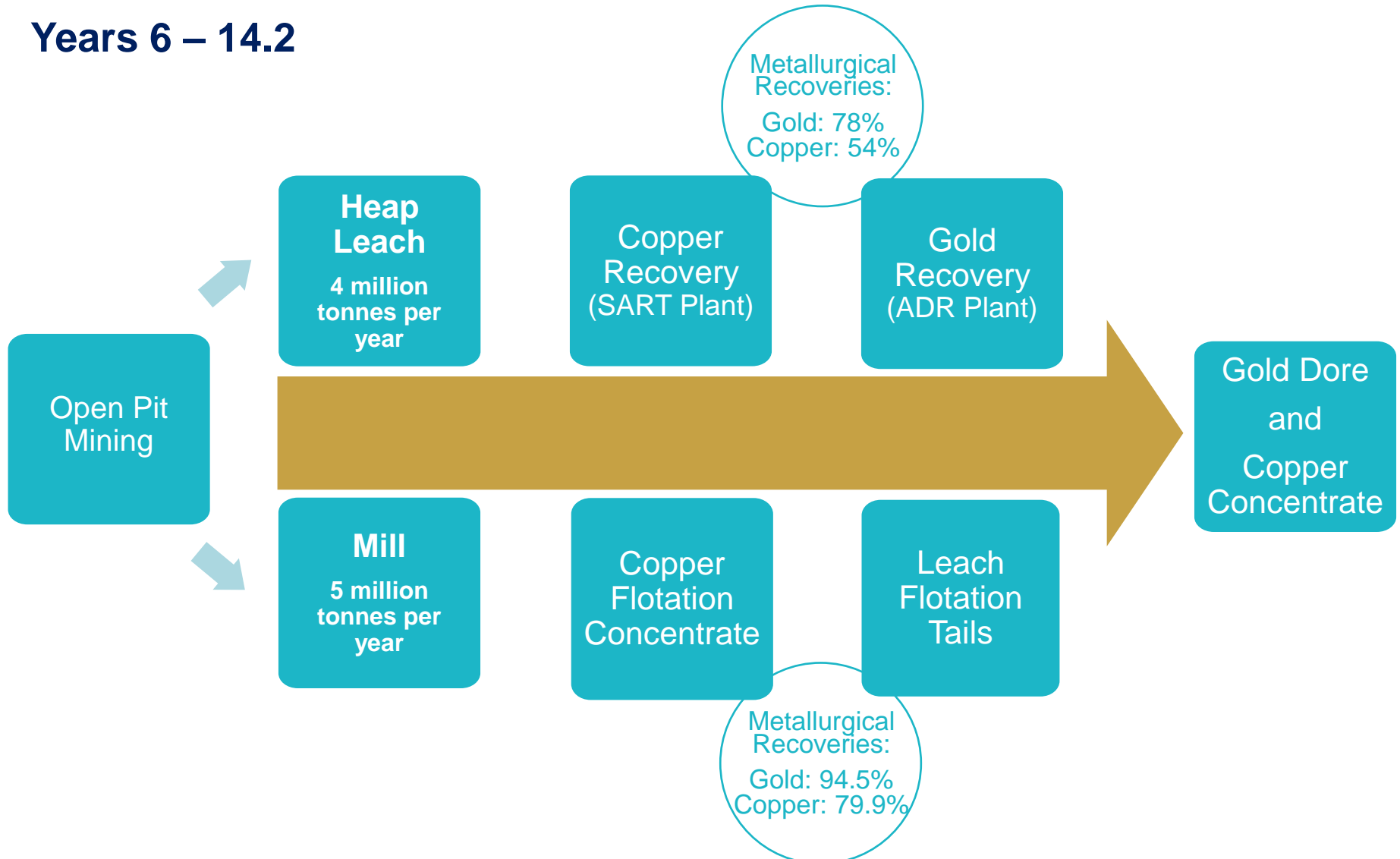

Figure 17-1 Gabbs Overall Heap Leach Process Flowsheet

(1) See the Gabbs Technical Report dated May 17, 2024 available under the Company's profile on SEDAR+ at www.sedarplus.com and on the Company's website at www.p2gold.com.

Gabbs Project 2024 PEA Plan of Operations⁽¹⁾

Years 6 – 14.2



(1) See the Gabbs Technical Report dated May 17, 2024 available under the Company's profile on SEDAR+ at www.sedarplus.com and on the Company's website at www.p2gold.com.

Gabbs Project Advancing to Production in Nevada

Gabbs Project Flow Sheet Mill (Years 6 – 14.2)⁽¹⁾

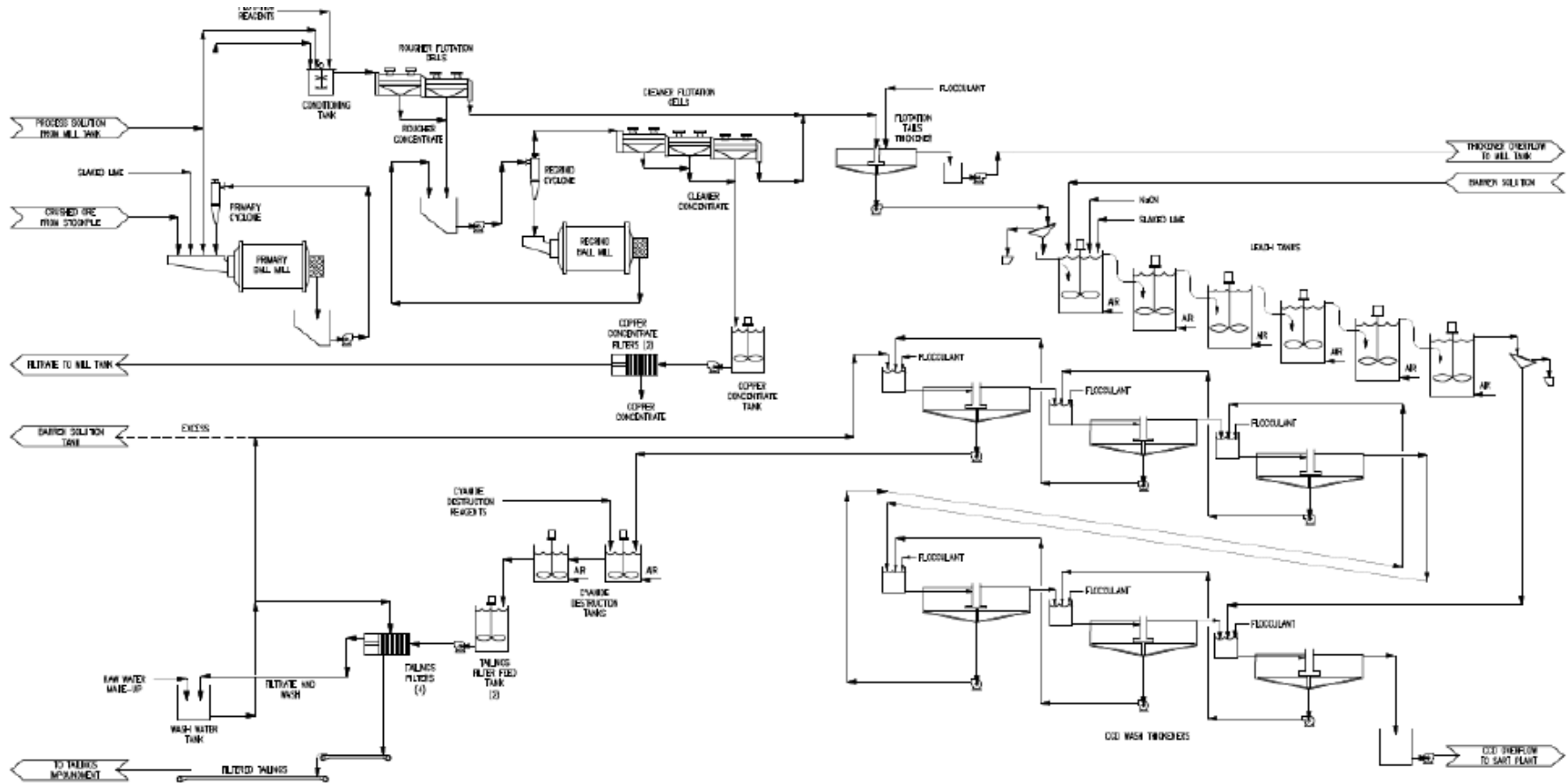

PRELIMINARY
NOT FOR CONSTRUCTION

Figure 17-2 Gabbs Overall Milling Process Flowsheet

(1) See the Gabbs Technical Report dated May 17, 2024 available under the Company's profile on SEDAR+ at www.sedarplus.com and on the Company's website at www.p2gold.com.

Gabbs Project 2024 PEA Production Metrics⁽¹⁾

LOM Gold Equivalent Production ⁽²⁾ (oz)	2.46 million
LOM Gold Production (oz)	1.47 million
LOM Silver Production (oz)	2.06 million
LOM Copper Production (t)	190 thousand
Average Annual Gold Equivalent Production ⁽³⁾ (oz)	174,000
Average Annual Gold Production (oz)	104,000
Average Annual Silver Production (oz)	145,000
Average Annual Copper Production (t)	13,500

(1) See P2 Gold news release dated May 22, 2024, and the Gabbs Technical Report dated May 17, 2024 available under the Company's profile on SEDAR+ at www.sedarplus.com and on the Company's website at www.p2gold.com.

(2) 125,345,274 tonnes grading 0.43 g/t gold, 1.09 g/t silver and 0.24% copper at base case metal prices of US\$1950/oz gold, US\$25.00/oz silver and US\$4.50/lb copper; LOM means life-of-mine

(3) LOM gold equivalent production over 14.2 years

Gabbs Project

2024 PEA Projected Processing and Production Summary⁽¹⁾

Year	Tonnes Process Ox/S ⁽²⁾ (k t)	Gold Grade Ox/S ⁽²⁾ (g/t)	Silver Grade Ox/S ⁽²⁾ (g/t)	Copper Grade Ox/S ⁽²⁾ (%)	Gold Production (k oz)	Silver Production (k oz)	Copper Production (t)	Gold Equivalent Production ⁽²⁾ (k oz)
1	9,000/ -	0.78/ -	1.68/ -	0.23/ -	150	186	9,464	201
2	9,000/ -	0.54/ -	1.28/ -	0.26/ -	130	174	12,233	194
3	9,000/ -	0.35/ -	0.96/ -	0.24/ -	86	131	11,858	148
4	9,000/ -	0.26/ -	1.17/ -	0.22/ -	63	148	11,028	121
5	9,000/ -	0.31/ -	1.16/ -	0.21/ -	69	151	10,352	124
6	4,000/ 5,000	0.52/ 0.52	1.40/ 1.27	0.22/ 0.29	133	194	17,195	223
7	4,000/ 5,000	0.35/ 0.41	0.72/ 1.09	0.19/ 0.26	100	135	14,437	175
8	4,000/ 5,000	0.43/ 0.43	0.89/ 1.20	0.23/ 0.26	107	146	15,314	187
9	4,000/ 5,000	0.47/ 0.47	0.72/ 1.20	0.26/ 0.27	118	140	16,081	202
10	4,000/ 5,000	0.36/ 0.36	0.60/ 0.90	0.25/ 0.26	93	109	15,832	175
11	4,000/ 5,000	0.25/ 0.37	0.55/ 1.08	0.23/ 0.33	83	119	18,055	176
12	4,000/ 5,000	0.51/ 0.36	1.21/ 1.11	0.16/ 0.26	102	153	14,047	175
13	4,000/ 5,000	0.67/ 0.49	1.39/ 0.95	0.21/ 0.18	139	155	11,698	201
14	2,317/ 5,000	0.20/ 0.42	0.64/ 0.85	0.14/ 0.21	84	99	10,446	138
15	-/ 1,028	-/ 0.45	-/ 0.88	-/ 0.20	16	18	1,917	26
Total					1,472⁽²⁾	2,058⁽²⁾	189,959⁽²⁾	2,466⁽²⁾

(1) See the Gabbs Technical Report dated May 17, 2024 available under the Company's profile on SEDAR+ at www.sedarplus.com and on the Company's website at www.p2gold.com.

(2) At Base Case Metal Prices / Sums may differ due to rounding / Ox/S means oxide mineralization/sulphide mineralization

Gabbs Project

2024 PEA Projected Mining and Production Summary

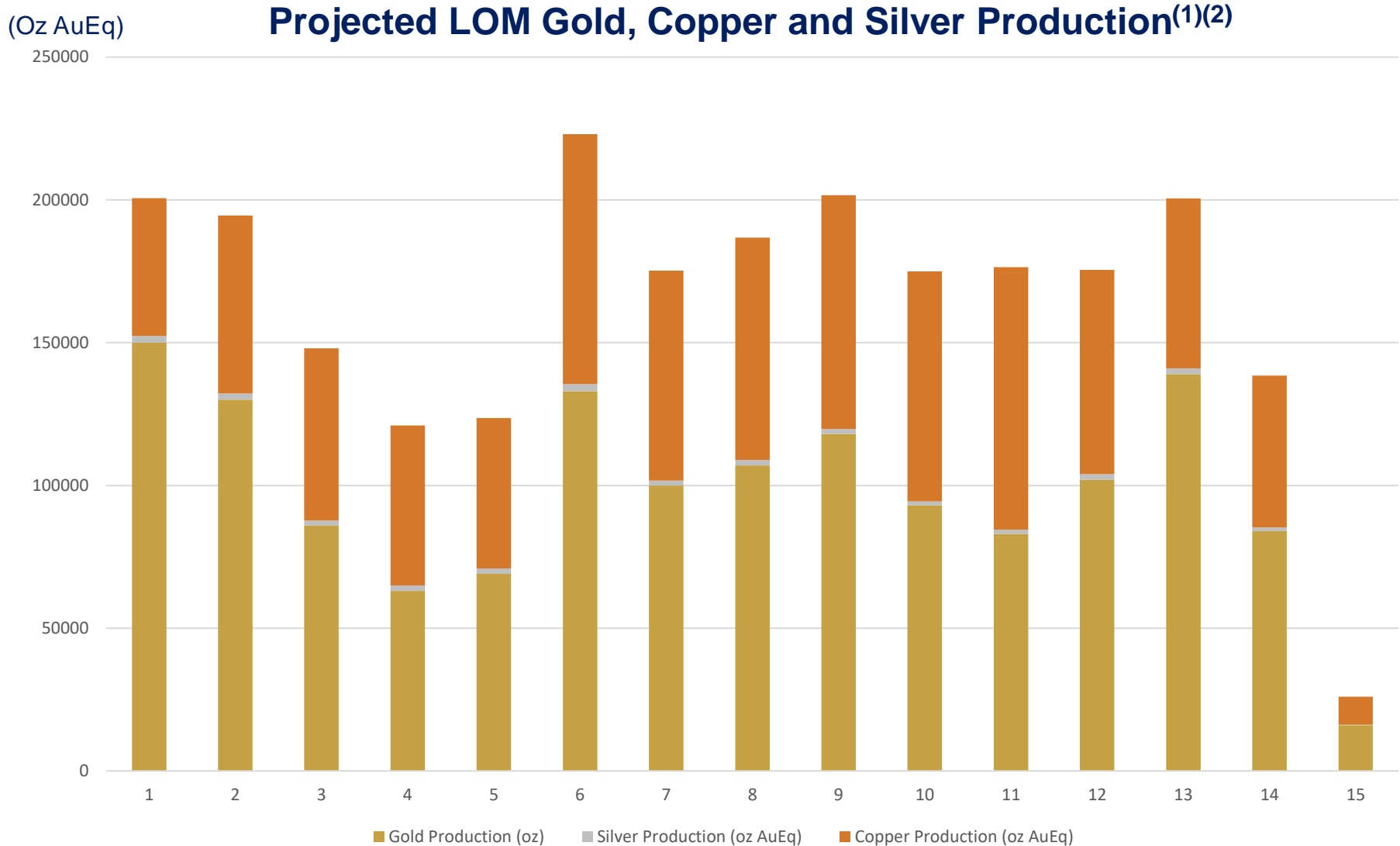

(1) Base case Metal Prices of US\$1950/oz gold, US\$25/oz silver and US\$4.50/lb copper / Sums may differ due to rounding

(2) See the Gabbs Technical Report dated May 17, 2024 available under the Company's profile on SEDAR+ at www.sedarplus.com and on the Company's website at www.p2gold.com.

Gabbs Project

Advancing to Production in Nevada



Gabbs Project 2024 PEA Capital Costs⁽¹⁾

Capital Costs	(US\$ in millions)
Mining (including contingency of 10%)	\$68.5
Process, Heap Leach (including contingencies of up to 25%)	\$204.8
Other (including contingencies)	\$92.2
Total Pre-Production Capital	\$365.5
Working capital and initial fills	\$14.2
Sustaining Capital (mill capital including contingencies)	\$343.2
Sustaining Capital (mining, other including contingencies)	\$141.7
Reclamation and Closure	\$56.4

(1) See P2 Gold news release dated May 22, 2024, and the Gabbs Technical Report dated May 17, 2024 available under the Company's profile on SEDAR+ at www.sedarplus.com and on the Company's website at www.p2gold.com.

Gabbs Project

Advancing to Production in Nevada



Gabbs Project 2024 PEA Operating Costs⁽¹⁾

Operating Costs	(US\$)
Mining (\$/tonne mined) ⁽²⁾	\$1.55
Heap Leach Processing (\$/tonne)	\$10.70
Mill Processing (\$/tonne)	\$13.64
G&A (\$/tonne)	\$0.73
AISC (co-product), LOM ⁽³⁾ (\$/oz Gold)	\$1,233.81

(1) See P2 Gold news release dated May 22, 2024, and the Gabbs Technical Report dated May 17, 2024 available under the Company's profile on SEDAR+ at www.sedarplus.com and on the Company's website at www.p2gold.com.

(2) Includes rehandle material

(3) Base Case Metal Prices of US\$1950/oz gold, US\$25/oz silver and US\$4.50/lb copper

Gabbs Project 2024 PEA Opportunities⁽¹⁾

- **Metallurgy** – complete additional test work to increase recoveries for gold and copper mineralization and evaluate the use of high-pressure grinding rollers for potential heap leaching of sulphide mineralization to increase recovery of free gold
- **Mine plan** – optimize mine sequencing to increase return on capital and carryout geotechnical drilling to optimize pit slope angles
- **Waste Stripping** – evaluate extent of alluvium in waste to reduce stripping cost
- **Equipment Lease** – evaluate leasing mining fleet versus upfront capital
- **Mineral Resource** – expand oxide and sulphide gold and gold and copper mineralization (zones remain open)
- **Contract Mining** – evaluate contract mining versus owner fleet
- **Capex** – evaluate equipment alternatives to reduce capital costs

(1) See P2 Gold news release dated May 22, 2024, and the Gabbs Technical Report dated May 17, 2024 available under the Company's profile on SEDAR+ at www.sedarplus.com and on the Company's website at www.p2gold.com.

Gabbs Project

Mineral Resource Estimate April 2024

April 2024 Mineral Resource Estimate⁽¹⁾⁽²⁾

Mineral Resource Category	Tonnes (M)	Gold Grade (g/t)	Silver Grade (g/t)	Copper Grade (%)	Gold (M oz)	Silver (M oz)	Copper (M lbs)	Gold Eq. Grade (g/t)	Gold Eq. (M oz)
Indicated	49.8	0.45	1.36	0.27	0.72	2.17	297.0	0.73	1.16
Inferred	112.2	0.35	0.84	0.23	1.28	3.04	567.1	0.63	2.29

Gold Equivalent (“AuEq”) breakdown of Gold and Copper Mineral Resources at \$1,838/oz Gold and \$3.96/lb Copper⁽¹⁾⁽²⁾

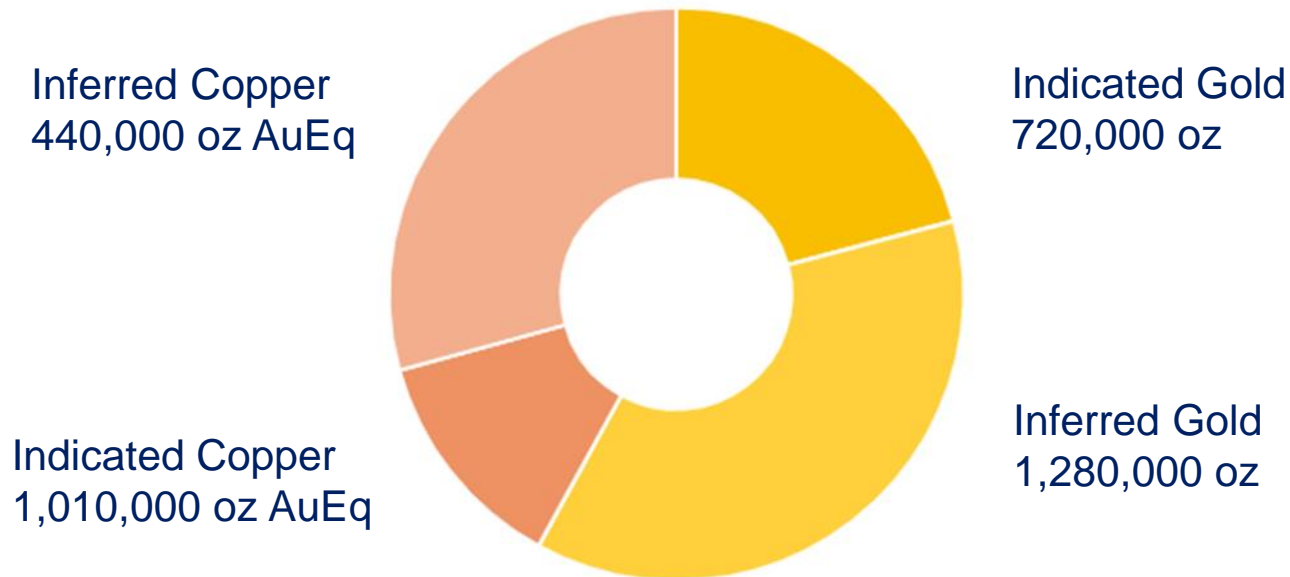

1) See P2 Gold news release dated April 29, 2024, and the Gabbs Technical Report dated May 17, 2024 available under the Company’s profile on SEDAR+ at www.sedarplus.com and on the Company’s website at www.p2gold.com.

2) Silver not included in gold equivalent calculation / Indicated Copper & Inferred Copper determined by subtracting Gold ounces from Gold Equivalent ounces.

Gabbs Project Mineral Resource Opportunities

■ **Expand Mineral Resource**

- All four known zones of mineralization outcrop and remain open
- Potential for other near surface zones of mineralization that do not outcrop
- Expansion potential at depth

■ **Upgrade Mineral Resource**

- Potential to increase grade as the recently drilled angled holes at higher grade than vertical historical holes
- Significant number of historical holes not assayed for both gold and copper

Gabbs Project Mineralized Zones - Plan View

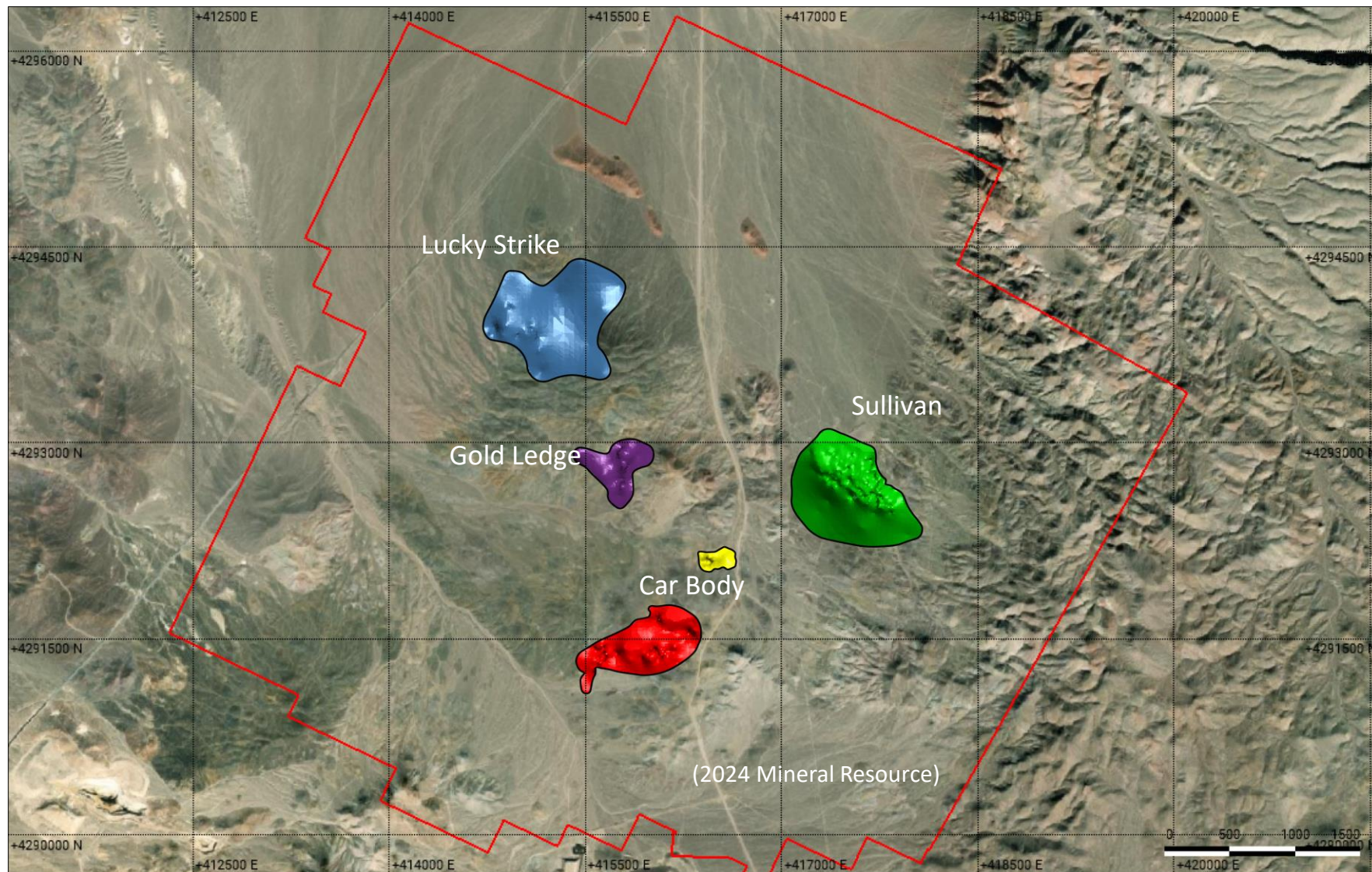

(1) See P2 Gold news release dated April 29, 2024, and the Gabbs Technical Report dated May 17, 2024 available under the Company's profile on SEDAR+ at www.sedarplus.com and on the Company's website at www.p2gold.com.

Gabbs Project 2024/25 Plans⁽¹⁾

- Optimize mine plan
- Re-permit water wells
- Metallurgical testing to investigate improving gold and copper recoveries in the heap leach process
- Metallurgical testing to investigate improving gold recoveries in the low-grade sulphide mineralization
- Continue environmental baseline collection
- File mining plan of operations with BLM
- Commence infill drill program
- Commence feasibility study
- Commence permitting

(1) Subject to availability of financing

Advancing Gabbs
Road and power accessible, good topography



Advancing Gabbs Planned Schedule for Production⁽¹⁾

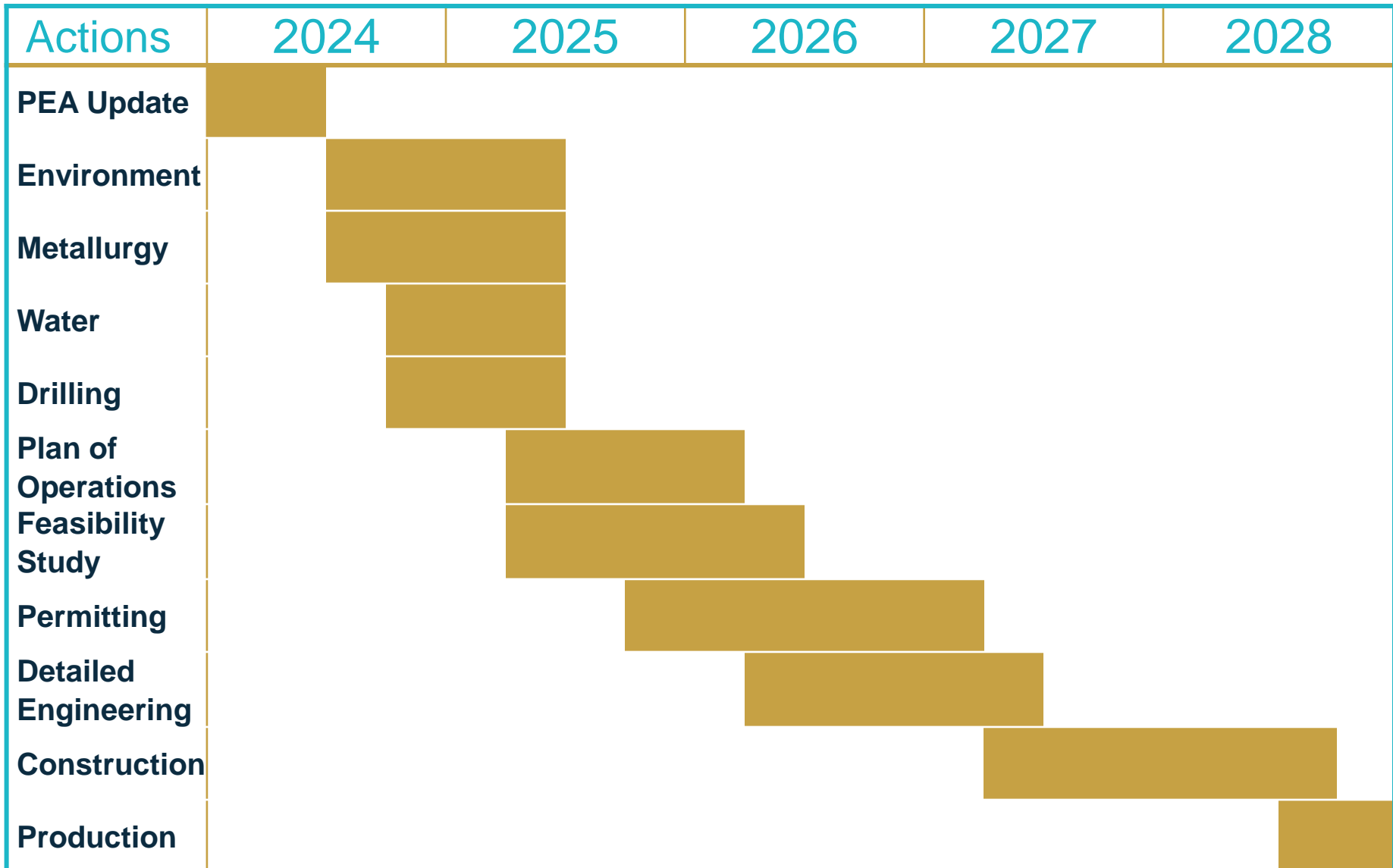

(1) Subject to availability of financing and permitting

P2 Gold Share Structure Cash and Ownership⁽¹⁾



Equity Structure

Issued and Outstanding	123,821,387
Stock Options Outstanding ⁽²⁾	7,053,333
Warrants Outstanding ⁽³⁾	51,880,705
Convertible Debenture Shares ⁽⁴⁾	23,785,714
Fully Diluted	206,541,139
Cash and Receivables at June 30, 2024⁽⁵⁾	\$305,888
Market cap at August 31, 2024	\$7.1 million

Equity Ownership

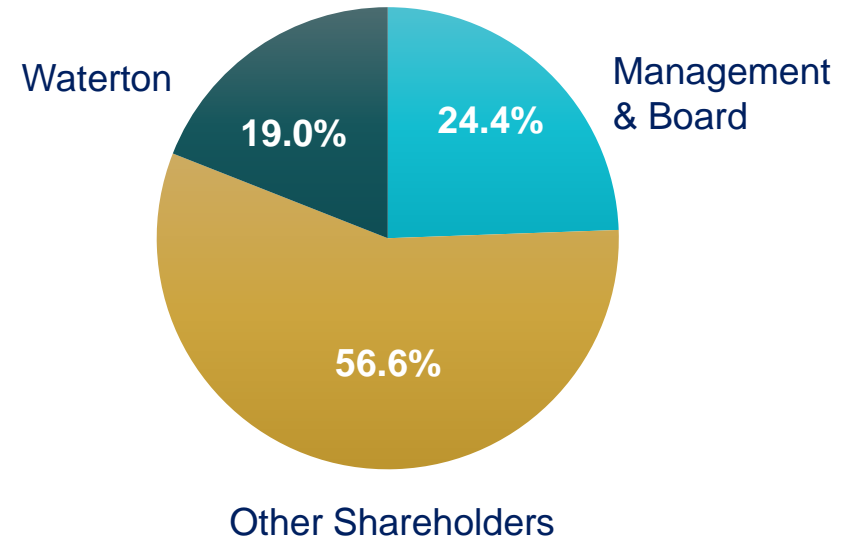

1) As of September 3, 2024; ownership calculated on an undiluted basis

2) Exercise prices range from \$0.08/share to \$0.25/share at September 3, 2024

3) 5,771,689 warrants exercisable at \$0.40/share until December 20, 2024; 2,537,414 warrants exercisable at \$0.40/share until December 21, 2024; 9,223,295 warrants exercisable at \$0.40/share until May 4, 2025; 785,632 warrants exercisable at \$0.40/share until May 31, 2025; 6,250,000 warrants exercisable at \$0.15/share until February 2, 2026; 17,025,000 warrants exercisable at \$0.15/share until March 4, 2026; 753,375 warrants exercisable at \$0.07/share until March 4, 2026; 3,787,500 warrants exercisable at \$0.15/share until March 14, 2026; 163,500 warrants exercisable at \$0.07/share until March 14, 2026; 5,000,000 warrants exercisable at \$0.10/share until September 3, 2026

4) \$1,665,000 of Convertible Debentures exercisable at \$0.07/share until January 31, 2025 and exercisable at \$0.10/share from February 1, 2025 to January 31, 2026

5) Upsized financing announced September 4, 2024 for \$900,000 at \$0.05/unit. Each unit includes a two-year warrant exercisable at \$0.10/share. See news release dated September 4, 2024.



TSX-V:PGLD
OTCQB:PGLDF
FRA:4Z9

P2 Gold Inc.
1100, 355 Burrard Street
Vancouver, BC
V6C 2G8
www.p2gold.com

Contact: Joe Ovsenek, President & CEO
jovsenek@p2gold.com

info@p2gold.com